



DRIVE ALIVE

SHOGUN SPORT





VERSATILE DIAMONDS

The world is full of challenges – deserts to cross, mountains to climb, seas to sail on. To meet those challenges takes a special kind of person, to reach them takes a special kind of car – a car which makes light work of towing and relishes the rough and tumble of adventure, unphased by tough terrain or fast-flowing water. So what do you do when your everyday life calls for an everyday car, but your other life calls for something altogether tougher? You could, of course, buy two cars; alternatively you could buy the supremely versatile Mitsubishi Shogun Sport – a blue-blooded off-roader which is equally at home on the road.





Model illustrated: Shogun Sport 2.5 TD Equippe

A RURAL WORKHORSE WITH FANCY MANNERS

Throughout the daily grind this muscular 4x4 exhibits exceptional road manners. Refined and easy to handle, whilst there is no denying that this is a pretty big car you quickly forget its size: the engines are willing and raring to go, and, whether you opt for the turbocharged diesel combined with a nicely weighted clutch and quick-change five-speed gearbox, or the smooth V6 petrol unit paired with a super-intelligent automatic transmission, they feel far more sprightly than the figures would lead you to believe. In fact, the Shogun Sport meets everyday challenges on the asphalt most gracefully – stable and long-legged on the highway, agile and appealing about town.







A GIANT ON THE HIGHWAY

Eager engines aside, the real key to taming tarmac is suspension and, whilst the Shogun Sport's system has proved itself in some of the world's toughest cross-country rallies, it is tuned for precise day-to-day handling and control. "Exceptionally controllable," say Auto Express, "there are few off-roaders that can be driven with such gusto." The brakes are powerful, the steering positive, and, whilst you sit much higher than in a traditional vehicle (a superior position which you'll rapidly grow to love), there the differences end. The Shogun Sport is a big off-roader which really does drive like an estate. Until, that is, you come to tow a trailer or venture into places where any estate fears to tread.



A SMOOTH OPERATOR IN THE ROUGH

The Shogun Sport's high stance, massive bumper and purposeful wheelarches are indicative of a vehicle equipped to tame more than tarmac and, whilst it certainly has what it takes to hit the highways, at heart it is born of the wild, often challenging even its famous big brother Shogun in international cross-country events. Yet its serious, sophisticated underpinnings are wrapped in a sleek, strong yet lightweight body, much of it made from high-tensile steel with exterior panels of rust-resistant galvanized steel, which means that it will always turn heads in the town, even after years of adventures in the rough.





Independent front suspension with both double-wishbones and torsion bar springs gives stable, controlled braking and cornering, maximising tyre tread contact and minimising brake dive. Multi-Link rear suspension – a triple-link torsion axle with coil springs and separate shock absorbers – ensures excellent vehicle control, even during rough off-road driving.



2H must be selected for driving on the highway, providing the best fuel economy and a smooth, quiet, comfortable ride, whilst 4H provides the extra traction needed for driving and towing on snow, sand or dirt roads. 4L gives extra torque, almost double that of 4H, for really extreme conditions like fording streams or climbing steep muddy banks.

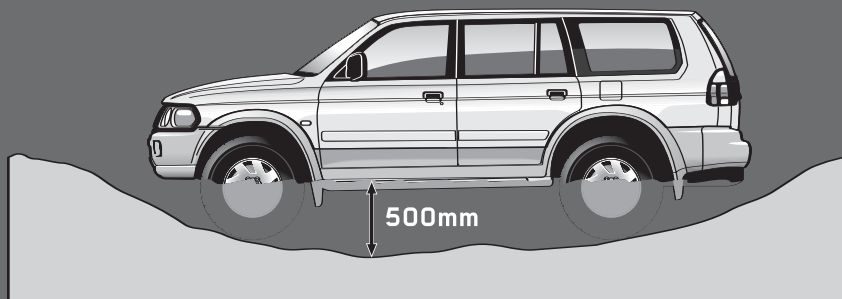

Maximum Wading depth

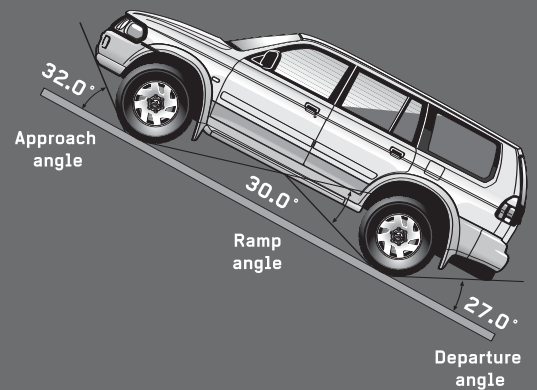

HERO UNDER THE SKIN

Competing in cross-country rallying often means speeding around a blind, gravel-strewn bend only to find the course change to clinging mud at the mid-point, and this is where the Shogun Sport's Easy Select four-wheel drive system has cut its teeth. A limited-slip differential helps to prevent tyre spin and the 'shift-on-the-fly' system means that you can switch from two- to four-wheel drive, or back again, with the flick of a lever at speeds of up to 62mph to instantly optimise traction on loose or slippery surfaces. Allied with excellent ground clearance and a supremely versatile transmission which delivers fine low-end torque, the Shogun Sport will conquer just about anything you are likely to encounter off-road.





Model illustrated: Shogun Sport 3.0 V6 Elegance

AMBIENCE AND ADVENTURE

Whether you're hitting the highways or the highlands you deserve some pampering and the Shogun Sport has plenty to satisfy even the most demanding souls: air conditioning^{*1} and a sunroof^{*2}, electrically operated heated door mirrors and power windows all round to name but a few; indeed, even if this were a top-of-the-range estate car the specification would be notably comprehensive. Of course, this isn't an estate, it's something far more exciting and one feature will always remind you of that – a multi-meter^{*3} located high on the central binnacle: its electronic compass may not be a necessity in the middle of town but it will focus your mind on all the fun you can have in your other life.

*1 A dealer fit option on Classic models. *2 Not Warrior *3 Not Classic models.



THE LUXURY OF SPACE

Since the Shogun Sport looks like a rather superior estate, and drives like one too, it will come as no surprise to learn that it also provides the versatility of an estate – a variety of seating combinations enabling you to alternate between passengers and cargo at will. And that extremely long wheelbase ensures that you always enjoy the greatest luxury of all – space. Even rear passengers, second-class citizens in many cars, enjoy enough elbow-, leg- and head-room to hold a party, whilst still leaving oceans of cargo room for their kit.





SUPREME VERSATILITY

60:40 split rear seats can be folded at will to greatly increase your cargo option, a fully flat function maximises cargo space. When you feel the need for a nap the front seatbacks recline flat to make a truly comfortable resting area.



WARRIORS RULE

If you really want to command attention, 18" alloy wheels and colour-keyed details on a bright silver or jet black body turn the ever-sleek Shogun Sport into a truly imposing Warrior. Step inside and you'll find that the vast cabin is enhanced by the sophisticated ambience of black leather stitched in silver and complimented by the sheen of titanium trim. Slip some cool sounds into the CD player and, whether you're gliding around the city streets, scaling the peaks or cruisin' the dunes, in this car all of your tribe can travel in the optimum style and comfort all of the time.





Model illustrated: Shogun Sport 3.0 V6 Warrior

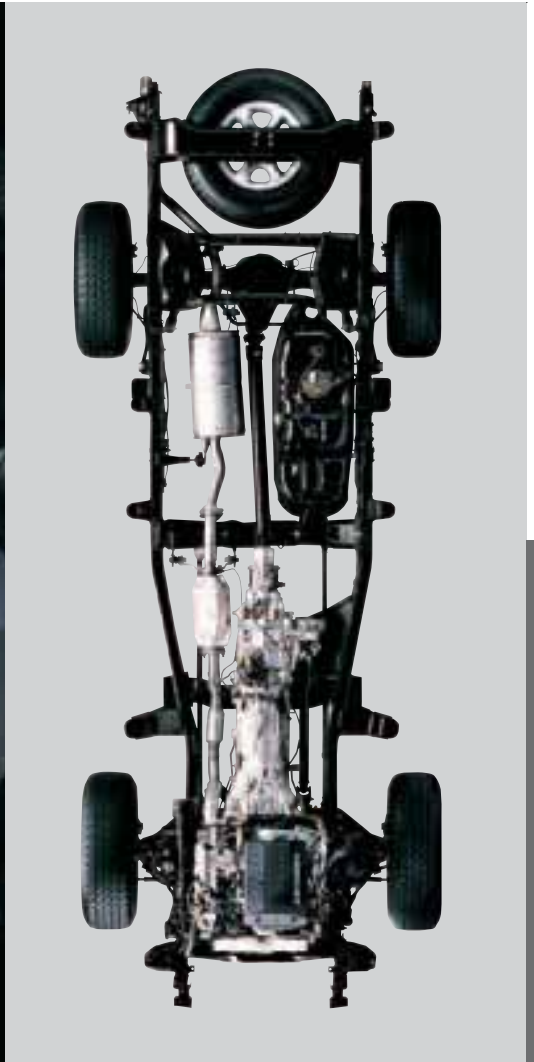

OPTIMUM PERFORMANCE AS STANDARD

Mitsubishi have long been acknowledged as a particularly clever engineering company and nowhere is this more evident than in its engines. If you need a real workhorse the 2.5 litre intercooled, turbocharged diesel is unbeatable: 114 bhp with plenty of punch throughout the rev range and incredible torque of 177 lb ft

at just 2000 rpm make it the ideal towing vehicle. Mated to this is a fast, accurate five-speed manual transmission which is smooth and satisfying to use.

For those who prefer petrol power the alternative 3.0 litre V6 delivers a silky 168 bhp. Designed for ultimate relaxation it is

partnered by probably the best automatic transmission available – Mitsubishi's INVECS II system. Here advanced computerised control is blended to a four-speed gearbox, enabling it to analyse your particular driving style and then emulate it – so it changes gear when you want, not when it thinks that you should.



In the 2.5 litre diesel engine a variable nozzle turbocharger ensures plenty of power at the top end for overtaking, whilst the 3.0 litre, 24-valve V6 boasts silky smooth acceleration right up to its 109 mph top speed.



The intelligent automatic – unlike a traditional automatic which changes gear at pre-programmed revs, Mitsubishi's INVECS II transmission learns from the driving style of everyone who sits behind the wheel and then adapts its shifting patterns accordingly – you'll think that it can read your mind.

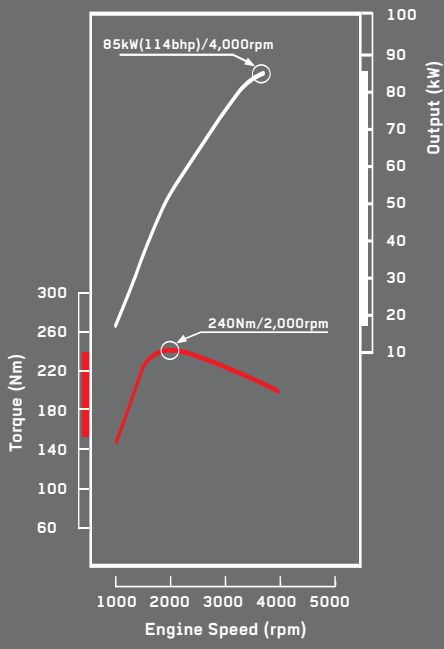

2.5 litre Intercooled Turbo Diesel





SAFETY FIRST AND FOREMOST

The Shogun Sport's high stance and excellent all-round vision allow you to both see and be seen whilst a load sensing proportioning valve aids safe stopping whatever the weight of your load and ABS brakes* with Electronic Brakeforce Distribution (EBD) ensure optimum braking distribution in a crisis. Should the unthinkable actually happen both the front and rear of the ladder frame chassis are designed to crumple in order to absorb impact, cross-members and side door impact bars aid in maintaining the integrity of the cabin space and dual SRS airbags further protect those in the front. Of course, anti-trapping power mechanisms and child-proof rear door locks are all standard, but then, you'd expect nothing less from a Mitsubishi.

*Not Classic models.



KEEP IT PERSONAL

Fearless off-road, nimble on the highway and genteel about town – the Shogun Sport is many cars wrapped into one, and you can create your own statement by adding a wide range of Mitsubishi Motors genuine accessories. In addition to those shown here there is a whole brochure-full to choose from, just ask your dealer for the Shogun Sport Accessories brochure. And remember, if fitted when new they all benefit from the same exceptional warranty as the vehicle itself.



1



2



3



4



5



6

1. Front guard
2. Reverse parking sensors and rear bumper corner protectors
3. Tow bar with wiring socket
4. Stainless steel door entry guards
5. Boot tray
6. Roof luggage carrier

Images are for illustrative purposes only
- designs may vary.

EXTERIOR AND INTERIOR



CLASSIC

The 2.5 litre turbodiesel Shogun Sport Classic's big, bold outline is accentuated with colour-keyed bumpers and boasts roof rails, side steps and mud flaps. It also features central locking, a sunroof, electrically operated, heated door mirrors, a stereo radio cassette with four speakers and power windows all round.



EQUIPPE AND ELEGANCE

The exterior of both the turbodiesel Equippe and V6 Elegance models is made even more distinctive by the addition of wheelarch extensions, side protector mouldings, 16" alloy wheels and a rear spoiler, whilst front fog lamps and headlamps washers aid your way and extra speakers and storage compartments together with air conditioning and a leather steering wheel add to the pampering. Full leather trim, an option on other models, is standard on the Elegance.





WARRIOR

The mean 'n' moody Warrior is available with either a 2.5 litre turbodiesel engine and manual transmission or V6 engine and INVECS II automatic and so includes most* of the striking features of the other Shogun Sport models, colour-keyed throughout in black or silver with 18" alloy wheels and special black leather interior trim.

*Please refer to Standard and Optional Equipment pages for full details.



4WORK

With its heavy-duty floor in place of the rear seats the Shogun Sport 4Work benefits from all the features of the Classic but, as a commercial vehicle, it enjoys an excellent tax advantage: even with fuel and unrestricted private mileage this vehicle only attracts tax on a benefit charge of £500; if used only to and from work no tax is incurred. Full details of 4Work vehicles are available from your Mitsubishi dealer.



4WORK



COLOUR OPTIONS



| Model | | Shogun Sport Classic | Shogun Sport Equippe | Shogun Sport Warrior | Shogun Sport Elegance |
|--|-----|---|----------------------|---|-----------------------|
| Interior Trim | | Dark Grey | Dark Grey | Dark Grey | Dark Grey |
| Exterior colour | | | | | |
| 1 Sterling Silver (M) | A19 | ■ | ■ | ■ | ■ |
| 2 Graphite Grey (P) | A72 | - | ■ | - | ■ |
| 3 Thunder Blue (P) | T65 | ■ | ■ | - | ■ |
| 4 Summit White (S) | W09 | ■ | ■ | - | ■ |
| 5 Knight Black (P) | X24 | ■ | ■ | ■ | ■ |
| 6 Thunder Blue (P)/Champagne Beige (M) | B9S | - | ■ | - | ■ |
| 7 Orient Red (P)/Champagne Beige (M) | P7S | - | ■ | - | ■ |
| 8 Knight Black (P)/Champagne Beige (M) | XBE | - | ■ | - | ■ |
| Seats | | Cloth (Dark Grey) | | Leather (Black) | |
| Door Trim | | Formed-type with Cloth Insert (Dark Grey) | | Formed-type with Leather Insert (Black) | |
| Headlining | | Non-woven Fabric (Light Grey) | | Non-woven Fabric (Light Grey) | |
| Floor Carpet | | Needle Punch (Grey) | | Needle Punch (Grey) | |

■ : Available M: Metallic* P: Pearlescent* S: Solid

*Metallic/Pearlescent paint finish available at additional cost.

OUTSTANDING AFTER SALES FOR CAREFREE MOTORING

More than 2500 Mitsubishi Motors Authorised Service Points in Europe are committed to helping you wherever you are.

PROFESSIONAL SERVICING

Even new cars require regular maintenance and servicing. Not just to guarantee your mobility, but also for the safety of you and your passengers. Trained professionals using specialist diagnostic equipment and genuine parts at your Mitsubishi Authorised Service Point are ready to oblige.

You'll be advised about the cost beforehand, so there will be no unpleasant surprises when you return to pick up your vehicle.

MITSUBISHI MOTORS GENUINE PARTS

Even the smallest technical faults can lead to accidents. Therefore, all Mitsubishi Motors Genuine Parts have been developed and tested to stringent quality standards. We recommend using Mitsubishi Motors Genuine Parts in order to maintain the safety and integrity of your vehicle and that of your passengers. Mitsubishi Motors Genuine Parts are available at all Mitsubishi Authorised Service Points.

COMPREHENSIVE WARRANTY – OBVIOUSLY

All new Mitsubishi vehicles come with a comprehensive 3-year unlimited mileage warranty as standard. The anti-corrosion perforation warranty covers rusting through for the first 6 years. The reliability statistics for Mitsubishi vehicles are impressive, but in the unlikely event that you do need help, we offer MAP.

MAP – FREE BREAKDOWN ASSISTANCE



Throughout the warranty period your vehicle is covered by Mitsubishi Assistance Package (MAP) roadside assistance. This cover extends to more than 30 countries throughout Europe so your mobility is guaranteed even when you are on holiday. Should you ever need assistance in the event of breakdown, accident, theft or

vandalism – wherever you are, 24 hours a day, 7 days a week – just call the number on your card and the problem will be fixed on the spot. If it's more serious, your car will be taken to the nearest Mitsubishi Authorised Service Point and you'll be offered services such as a hotel, continuation of journey, a replacement car and vehicle repatriation. And if you continue to have your vehicle serviced at a Mitsubishi Authorised Service Point after the first three years, your mobility will be guaranteed for an additional year or up to the next service interval (whichever comes first) until your vehicle is 10 years old.

MAJOR SPECIFICATIONS

| Model | | Shogun Sport 2.5 TD Classic Manual | Shogun Sport 2.5 TD Equippe Manual | Shogun Sport 2.5 TD Warrior Manual | Shogun Sport 3.0 V6 Warrior Automatic | Shogun Sport 3.0 V6 Elegance Automatic | |
|---|-------------------|--|--|--|---|--|--|
| Engine/Electrics | | | | | | | |
| Engine type | | In-line 4-cylinder 8-valve SOHC diesel engine, 'variable nozzle' turbocharger with intercooler | | | V6 24-valve SOHC petrol engine, 6 cylinder, 60° configuration, roller rocker arms | | |
| Fuel system | | Indirect fuel injection through a Rotary VE type pump. Electronic 'quick glow' start | | | Electronically-controlled multi-point fuel injection (ECI-MULTI) | | |
| Displacement | cc | 2477 | 2477 | 2477 | 2972 | 2972 | |
| Bore/stroke | mm | 91.1 x 95.0 | 91.1 x 95.0 | 91.1 x 95.0 | 91.1 x 76.0 | 91.1 x 76.0 | |
| Compression ratio | | 21.0:1 | 21.0:1 | 21.0:1 | 9.0:1 | 9.0:1 | |
| Max. output | kw (bhp) at rpm | 85 (114)/4000 | 85 (114)/4000 | 85 (114)/4000 | 125 (168)/5000 | 125 (168)/5000 | |
| Max. torque | Nm (lb.ft) at rpm | 240 (177)/2000 | 240 (177)/2000 | 240 (177)/2000 | 255 (188)/4500 | 255 (188)/4500 | |
| Performance/Fuel Consumption/Emissions | | | | | | | |
| Maximum speed | | 93 (150) | 93 (150) | 93 (150) | 109 (175) | 109 (175) | |
| Acceleration 0-62 mph | | 16.8 | 16.8 | 16.8 | 14.5 | 14.5 | |
| Fuel type | | Diesel | Diesel | Diesel | Unleaded | Unleaded | |
| Fuel consumption | | 13.0 (21.7) | 13.1 (21.6) | 13.0 (21.7) | 17.1 (16.5) | 17.1 (16.5) | |
| lts/100km (mpg) | | 8.8 (32.1) | 9.0 (31.4) | 8.8 (32.1) | 11.2 (25.2) | 11.2 (25.2) | |
| | | 10.4 (27.2) | 10.5 (26.9) | 10.4 (27.2) | 13.4 (21.1) | 13.4 (21.1) | |
| CO ₂ emissions | | 275 | 278 | 275 | 319 | 319 | |
| Noise level, moving | | 74 | 74 | 74 | 71 | 71 | |
| Suspension and Steering | | | | | | | |
| Front axle | | Independent double wishbone, torsion bar springs, stabiliser bar, telescopic shock absorbers | | | | | |
| Rear axle | | 1 piece axle, rigid 3 link coil springs, stabiliser bar, telescopic shock absorbers | | | | | |
| Brakes | | Power assisted, tandem vacuum booster and load sensing proportioning valve | | | | | |
| | | Anti-lock Braking System with Electronic Brakeforce Distribution (ABS + EBD) | | | | | |
| Front | | 10.9" | 12.4" | 10.9" | 12.4" | 12.4" | |
| | | Ventilated discs with 2-pot calipers | | | Ventilated discs with 2-pot calipers | | |
| Rear | | 12.4" Solid discs with internal drum handbrake | | | | | |
| Steering | | Recirculating ball and nut, power assisted | | | | | |
| Min. turning circle | | 11.8 (38.7) | 11.8 (38.7) | 11.8 (38.7) | 11.8 (38.7) | 11.8 (38.7) | |
| Tyres | | P235/75R15 | 245/70R16 | 255/55R18 | 255/55R18 | 245/70R16 | |
| Wheels | | 15x6.0JJ steel | 16x7.0JJ alloy | 18x8.5JJ alloy | 18x8.5JJ alloy | 16x7.0JJ alloy | |
| Driveline/Transmission | | Easy Select part-time 4WD system with limited-slip rear differential | | | | | |
| Type | | Single dry plate clutch with hydraulic action | | | | | |
| Clutch | | Manual | | | Automatic | | |
| Automatic | | - | - | - | Torque converter with lock-up | | |
| Transmission | | Manual | Manual | Manual | Automatic | Automatic | |
| Manual | | 5-speed | 5-speed | 5-speed | - | - | |
| Automatic | | - | - | - | 4-speed with INVECS II | | |
| Gear ratios | | 1st | 3.918 | 3.918 | 3.918 | 2.842 | |
| | | 2nd | 2.261 | 2.261 | 2.261 | 1.495 | |
| | | 3rd | 1.395 | 1.395 | 1.395 | 1.000 | |
| | | 4th | 1.000 | 1.000 | 1.000 | 0.731 | |
| | | 5th | 0.829 | 0.829 | 0.829 | - | |
| | | Reverse | 3.925 | 3.925 | 3.925 | 2.720 | |
| Transfer gear ratio | | High | 1.000 | 1.000 | 1.000 | 1.000 | |
| | | Low | 1.925 | 1.925 | 1.925 | 1.900 | |
| Final gear ratio | | 4.636 | | 4.900 | 4.636 | 4.636 | |
| Dimensions | | | | | | | |
| Cargo room l x w x h | | 970 x 1360 x 970 | 970 x 1360 x 885 | 970 x 1360 x 970 | 970 x 1360 x 885 | 970 x 1360 x 885 | |
| Cargo capacity min. | | 545 (19.2) | 500 (17.6) | 545 (19.2) | 500 (17.6) | 500 (17.6) | |
| max. | | 1660 (58.5) | 1590 (56.1) | 1660 (58.5) | 1590 (56.1) | 1590 (56.1) | |
| Exterior l x w x h | | 4610 x 1695 x 1765 | 4610 x 1775 x 1780 | 4610 x 1775 x 1765 | 4610 x 1775 x 1780 | 4610 x 1775 x 1780 | |
| Ground clearance (unladen) | | 205 | 220 | 205 | 220 | 220 | |
| Track Front | | 1420 | 1465 | 1420 | 1465 | 1465 | |
| Rear | | 1435 | 1480 | 1435 | 1480 | 1480 | |
| Wheelbase | | 2725 | 2725 | 2725 | 2725 | 2725 | |
| Approach angle | | 29 | 32 | 29 | 32 | 32 | |
| Departure angle | | 24 | 27 | 24 | 27 | 27 | |
| Ramp breakover | | 27 | 30 | 27 | 30 | 30 | |
| Weights/Volumes | | | | | | | |
| Seating capacity | | 5 | 5 | 5 | 5 | 5 | |
| Fuel tank capacity | | 74 (16.3) | 74 (16.3) | 74 (16.3) | 74 (16.3) | 74 (16.3) | |
| Gross vehicle weight | | 2510 (5534) | 2510 (5534) | 2510 (5534) | 2510 (5534) | 2510 (5534) | |
| Kerb weight | | 1840 (4057) | 1915 (4222) | 1840 (4057) | 1865 (4112) | 1865 (4112) | |
| Towing capacity, braked | | 2800 (6173) | 2800 (6173) | 2800 (6173) | 2800 (6173) | 2800 (6173) | |
| Trailer nose weight | | 115 (254) | 115 (254) | 115 (254) | 115 (254) | 115 (254) | |
| Roof loading capacity | | 100 (220) | 100 (220) | 100 (220) | 100 (220) | 100 (220) | |
| Servicing/Insurance/Warranty | | | | | | | |
| Service intervals | | 4500 miles/6 months, 9000 miles/6 months then every 9000 miles or 12 months, whichever occurs first | | | Every 9000 miles or 12 months, whichever occurs first | | |
| Insurance group | | 14D | 14D | 14D | 16D | 16D | |
| Warranty | | 3 year unlimited mileage warranty, 6 year anti-corrosion perforation warranty and 3 year pan-European roadside, home and accident assistance | | | | | |

STANDARD AND OPTIONAL EQUIPMENT

| Model | Shogun Sport 2.5 TD Classic Manual | Shogun Sport 2.5 TD Equippe Manual | Shogun Sport 2.5 TD Warrior Manual | Shogun Sport 3.0 V6 Warrior Automatic | Shogun Sport 3.0 V6 Elegance Automatic |
|---|--|--|--|---|--|
| Security and Safety Features | | | | | |
| Security | | | | | |
| Immobiliser, engine | ■ | ■ | ■ | ■ | ■ |
| Locking wheel nuts | - | ■ | ■ | ■ | ■ |
| Luggage cover, retractable | ■ | ■ | ■ | ■ | ■ |
| Visible VIN | ■ | ■ | ■ | ■ | ■ |
| Safety | | | | | |
| ABS with EBD | - | ■ | ■ | ■ | ■ |
| Airbag SRS, driver's and front passenger's | ■ | ■ | ■ | ■ | ■ |
| Child proof rear door locks | ■ | ■ | ■ | ■ | ■ |
| Disc brakes, ventilated front, solid rear | ■ | ■ | ■ | ■ | ■ |
| Electric windows, anti-trapping, front and rear | ■ | ■ | ■ | ■ | ■ |
| Electric sunroof, anti-trapping | ■ | ■ | - | - | ■ |
| Fog lamp with auto-off function, rear | ■ | ■ | ■ | ■ | ■ |
| Head restraints, height adjustable x 5 | ■ | ■ | ■ | ■ | ■ |
| High-mount stop lamp, rear | ■ | ■ | ■ | ■ | ■ |
| Skid plate reinforced, front | ■ | ■ | ■ | ■ | ■ |
| Seatbelts 3-point ELR x2, front | ■ | ■ | ■ | ■ | ■ |
| Seatbelts, 3 point ELR/ALR X 3, rear | ■ | ■ | ■ | ■ | ■ |
| Side impact door bars | ■ | ■ | ■ | ■ | ■ |
| Steering column, collapsible and tilt adjustable | ■ | ■ | ■ | ■ | ■ |
| Exterior Features | | | | | |
| Styling | | | | | |
| Air scoop for intercooler, bonnet-mounted | ■ | ■ | ■ | - | - |
| Alloy wheels with locking wheel nuts | - | ■ | ■ | ■ | ■ |
| Bumpers, colour keyed, front and rear | ■ | ■ | ■ | ■ | ■ |
| Door mirrors and handles, black | ■ | ■ | - | - | ■ |
| Door mirrors and handles, colour keyed | - | - | ■ | ■ | - |
| Metallic or pearlescent paint finish | □ | □ | ■ | ■ | □ |
| Mudflaps, front and rear | ■ | ■ | ■ | ■ | ■ |
| Roof rails, black | ■ | ■ | ■ | ■ | ■ |
| Rear spoiler, colour keyed | - | ■ | ■ | ■ | ■ |
| Side protector mouldings, colour keyed | - | ■ | - | - | ■ |
| Side steps, with colour keyed supports | - | ■ | - | ■ | ■ |
| Side steps, with black supports | ■ | - | - | - | - |
| Spare wheel, steel, underfloor-mounted | ■ | ■ | - | - | ■ |
| Spare wheel, alloy, underfloor-mounted | - | - | ■ | ■ | - |
| Two-tone paint finish | - | □ | - | - | □ |
| Wheelarch extensions, colour-keyed | - | ■ | ■ | ■ | ■ |
| Functional | | | | | |
| Central door locking including tailgate | ■ | ■ | ■ | ■ | ■ |
| Door mirrors, electric heated with folding function | ■ | ■ | ■ | ■ | ■ |
| Fog lamps, reflector type, front | - | ■ | ■ | ■ | ■ |
| Headlamp washers | - | ■ | - | ■ | ■ |
| Towing hooks, front and rear | ■ | ■ | ■ | ■ | ■ |
| Tailgate pull-down handle | ■ | ■ | ■ | ■ | ■ |
| Wipers, variable intermittent with washer, front | ■ | ■ | ■ | ■ | ■ |
| Wiper, intermittent with washer, rear | ■ | ■ | ■ | ■ | ■ |
| Window demister with timer, rear | ■ | ■ | ■ | ■ | ■ |
| Interior Features | | | | | |
| Audio | | | | | |
| Aerial, electric with half-height switch, front wing | ■ | - | ■ | - | - |
| Aerial, flexible mast type, rear roof | - | ■ | - | ■ | ■ |
| Navigation system | DFO | DFO | DFO | DFO | DFO |
| Stereo radio/cassette with 6 speakers | ■ | ■ | - | - | ■ |
| Stereo radio/CD with 6 speakers | - | - | ■ | ■ | - |
| Styling | | | | | |
| Dashboard trim and window switch panels, titanium finish | ■ | - | ■ | ■ | - |
| Dashboard trim and window switch panels, black wood effect | - | ■ | - | - | ■ |
| Floor mats – with logo | - | - | ■ | ■ | - |
| Luggage area, needle punch carpet | ■ | - | ■ | - | - |
| Luggage area, cut pile carpet including wheelarch trim | - | ■ | - | ■ | ■ |
| Needle punch floor carpet | ■ | ■ | ■ | ■ | ■ |
| Seat trim, armrest and door inserts, fabric, dark grey | ■ | ■ | - | - | - |
| Seat trim, armrest and door inserts, leather, black | □ | □ | - | - | ■ |
| Seat trim, armrest and door inserts, leather, black with silver stitching | - | - | ■ | ■ | - |
| Steering wheel, 4-spoke | ■ | - | ■ | - | - |
| Steering wheel, 4-spoke, leather-trimmed | - | ■ | - | ■ | ■ |
| Convenience | | | | | |
| Access support grips, passengers, front and rear | ■ | ■ | ■ | ■ | ■ |
| Accessory socket, floor console | - | ■ | - | ■ | ■ |
| Accessory socket, luggage area | ■ | ■ | ■ | ■ | ■ |
| Console boxes, overhead x3 | - | - | ■ | ■ | - |
| Door pockets, front | ■ | ■ | ■ | ■ | ■ |
| Floor console box with front armrest | ■ | ■ | ■ | ■ | ■ |
| Floor console with front cup holders | ■ | ■ | ■ | ■ | ■ |
| Front seat backrest pockets | ■ | ■ | ■ | ■ | ■ |

■ : Standard □ : Option at additional cost - : Not available DFO : Dealer Fit Option at additional cost

STANDARD AND OPTIONAL EQUIPMENT

| Model | Shogun Sport 2.5 TD Classic Manual | Shogun Sport 2.5 TD Equippe Manual | Shogun Sport 2.5 TD Warrior Manual | Shogun Sport 3.0 V6 Warrior Automatic | Shogun Sport 3.0 V6 Elegance Automatic |
|---|--|--|--|---|--|
| Interior Features continued | | | | | |
| Convenience | | | | | |
| Footrest, driver's | - | - | - | ■ | ■ |
| Glove box | ■ | ■ | ■ | ■ | ■ |
| Illuminated ignition keyhole with time delay | ■ | ■ | ■ | ■ | ■ |
| Luggage net | - | ■ | - | - | ■ |
| Luggage tie-down hooks | ■ | ■ | ■ | ■ | ■ |
| Luggage area under-floor compartments | - | ■ | - | ■ | ■ |
| Luggage cover, retractable | ■ | ■ | ■ | ■ | ■ |
| Retractable assist grips x3 with coat hangers x2 | ■ | ■ | ■ | ■ | ■ |
| Sunvisors with vanity mirrors, driver's and passenger's | ■ | ■ | ■ | ■ | ■ |
| Functional | | | | | |
| Air conditioning, manual | - | ■ | ■ | ■ | ■ |
| Digital clock, overhead type | ■ | ■ | ■ | ■ | ■ |
| Electric glass tilt/slide sunroof | ■ | ■ | - | - | ■ |
| Electric heated door mirrors with folding function | ■ | ■ | ■ | ■ | ■ |
| Electric windows, front and rear with driver's side one-touch control | ■ | ■ | ■ | ■ | ■ |
| Fuel lid opener, remote | ■ | ■ | ■ | ■ | ■ |
| Headlamp levelling device | ■ | ■ | ■ | ■ | ■ |
| Instrument panel dimmer | ■ | ■ | ■ | ■ | ■ |
| Lights-on warning buzzer | ■ | ■ | ■ | ■ | ■ |
| Multi-meter (External temperature/compass/oil pressure/voltmeter) | - | ■ | ■ | ■ | ■ |
| Odometer/trip meter with digital display | ■ | ■ | ■ | ■ | ■ |
| Steering wheel, tilt adjustable | ■ | ■ | ■ | ■ | ■ |
| Tachometer | ■ | ■ | ■ | ■ | ■ |
| 4WD drivetrain mode indicator | ■ | ■ | ■ | ■ | ■ |
| Lighting | | | | | |
| Door courtesy lamps, front | ■ | ■ | ■ | ■ | ■ |
| Interior lamp, rear | ■ | ■ | ■ | ■ | ■ |
| Luggage/cargo area lamp | ■ | ■ | ■ | ■ | ■ |
| Map reading lamps, front | ■ | ■ | ■ | ■ | ■ |
| Seats | | | | | |
| 60/40 split-folding rear seats | ■ | ■ | ■ | ■ | ■ |
| Driver's seat height adjustment | ■ | ■ | ■ | ■ | ■ |
| Front seats, sliding/reclining with fully-flat function | ■ | ■ | ■ | ■ | ■ |
| Head restraints, height adjustable x5 | ■ | ■ | ■ | ■ | ■ |
| Rear seats, reclining with fully-flat function | ■ | ■ | ■ | ■ | ■ |
| Seatbelts 3-point ELR x2, front | ■ | ■ | ■ | ■ | ■ |
| Seatbelts, 3 point ELR/ALR X 3, rear | ■ | ■ | ■ | ■ | ■ |

■ : Standard □ : Option at additional cost - : Not available DFO : Dealer Fit Option at additional cost

DIMENSIONAL VIEWS

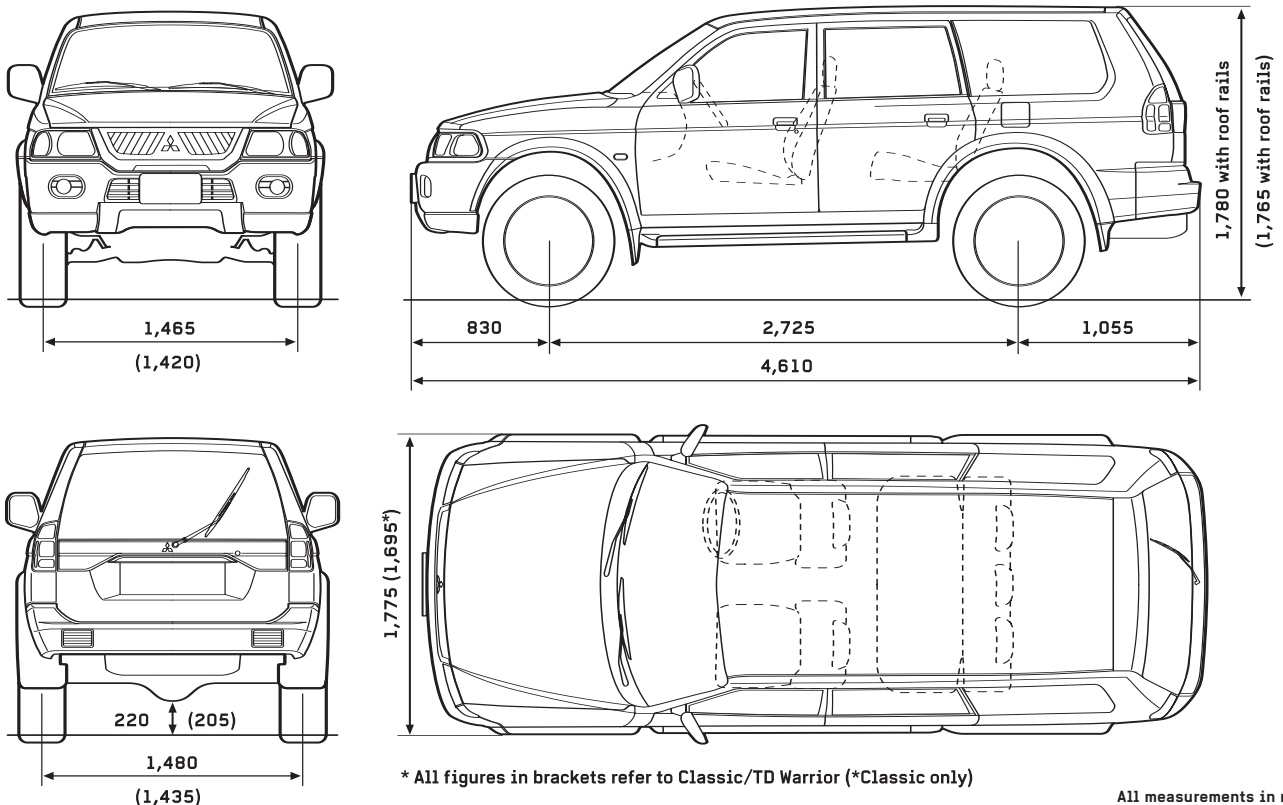

All measurements in millimetres.



DRIVE ALIVE IS OUR MOTTO.

It's the reason our designers and engineers go to work everyday. Statistics show that you are going to spend 'years of your life' in your car. We want those 'years' to be as pleasurable and as rewarding for you as possible. We want to ensure that every time you're driving and put your foot down on the accelerator, or catch a glimpse of yourself reflected... you will want to smile. Smile to really feel alive... to really drive alive.

Mitsubishi Motors Europe BV
www.mitsubishi-motors-europe.com

Specifications and warranty conditions may vary for overseas markets. For personal export, NATO or diplomatic sales, please refer to the appropriate 'Export Department' as follows:
U.K.: The Colt Car Company Ltd., Watermoor, Cirencester, Glos. GL7 1LF. Tel: 01285 655777.
Germany: The Colt Car Company Ltd., P.O. Box 1244, 41374 Brüggen, Germany. Tel: 02163 7036.

The specification of the vehicles illustrated in this publication may not be applicable to the UK market, furthermore some vehicle illustrations may include accessory items which are not part of UK standard specification. However, every effort has been made to ensure that the written information was accurate, up-to-date and consistent with UK specification at the time of going to press. The right is reserved to change specification, features and prices without prior notice. To avoid any misunderstandings, your Mitsubishi Motors dealer will advise of any alterations made since the date of issue of this brochure. No part of this publication may be reproduced in any form or by any means, without the prior written permission of The Colt Car Company Limited.

Head Office: The Colt Car Company Ltd., Watermoor, Cirencester, Glos. GL7 1LF
Tel: 01285 655777 Fax: 01285 658026 Website: www.mitsubishi-cars.co.uk

SPOR5006 08/05