

DRIVE ALIVE

GRANDIS DIESEL

A GEM OF A CAR

Life is often about compromise: a career compromise between personal fulfilment and financial gain, and a logistical compromise between the need to work and the time to play. But at least you no longer need to compromise about your car. With its seductive good looks, city-nipper driving style and full-sized MPV capacity the Mitsubishi Grandis balances passion and practicality all by itself.





GRANDIS

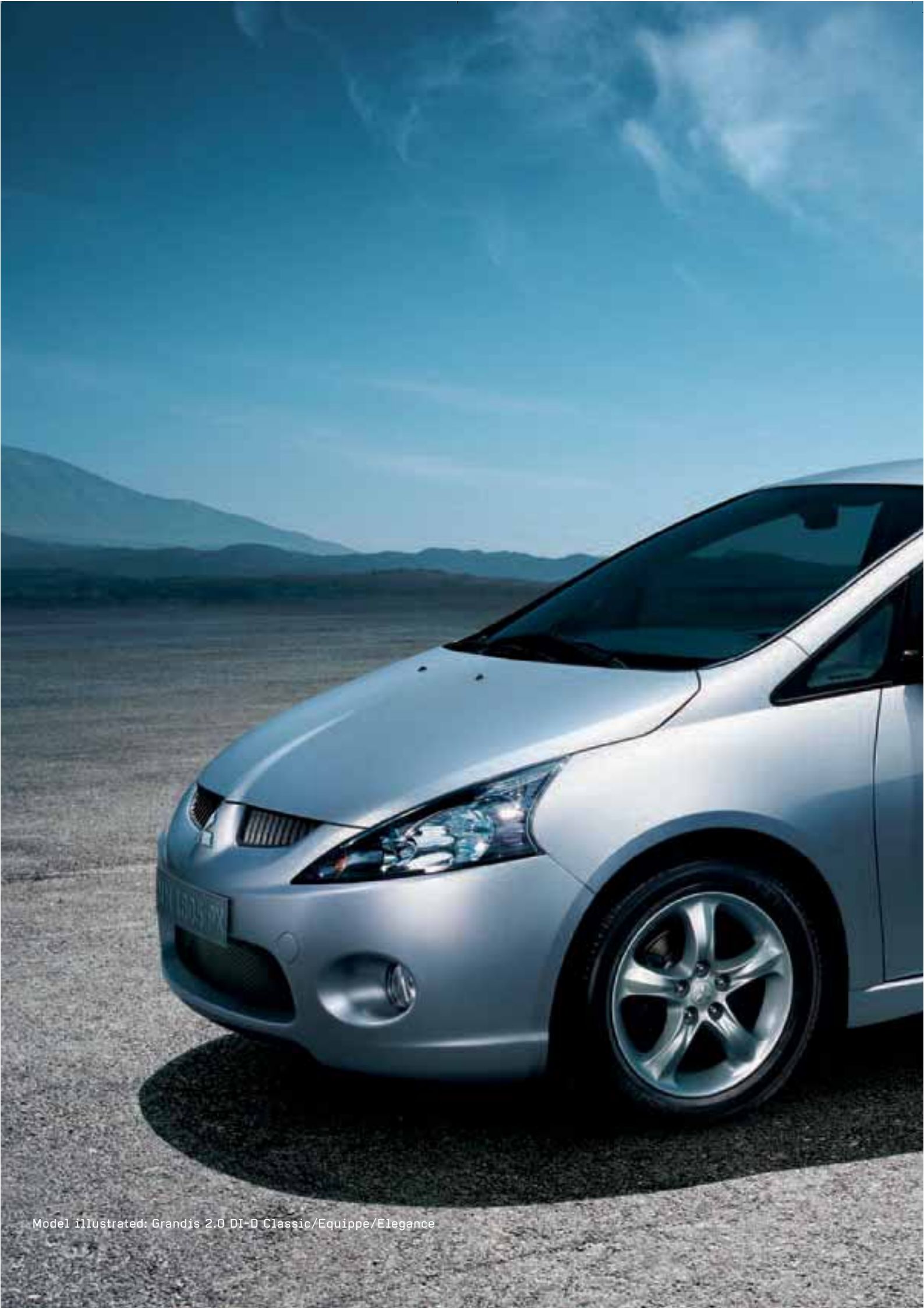

Model illustrated: Grandis 2.0 DI-D Classic/Equippe/Elegance

AN ART FORM IN ITS OWN RIGHT

Let's be frank: MPV's aren't usually renowned for their style. The need to fit seven seats into a vehicle of road-friendly proportions has resulted in cars known more for their van-like appearance than their ability to engender envy as you drive down the road. Until the Grandis, that is. Without question this is the future in family transport – svelte, sleek, shapely, its smooth planes and subtle curves blending together into a harmony of light and shade which is the essence of Japanese art. And, being that best of all Japanese automotive art forms – a Mitsubishi – it will look and feel just as good when lesser cars are seriously showing their age.



REDISCOVER THE DELIGHTS OF THE ROAD.

When you are driven by the need to transport lots of people or paraphernalia you may assume that your days of driving for sheer pleasure are over. Not so. In fact, take a Grandis out to play and you'll soon forget that you are driving an MPV – a feisty yet frugal 2.0 litre turbo-diesel engine and equally impressive 6-speed gearbox, confident cornering, positive power steering and a surprisingly tight turning circle mean that the Grandis is not only easier to handle and park than you could ever imagine an MPV would be, it's also far more fun. And when road conditions are less than ideal Mitsubishi's Active Stability and Traction Control System* comes to your aid – controlling the throttle and brakes on your behalf for optimum grip.

*Equipe/Elegance models only









A Driver only with EBD



B With passengers with EBD



C With passengers without EBD



* Brake-force equal to A

** Brake-force greater than A

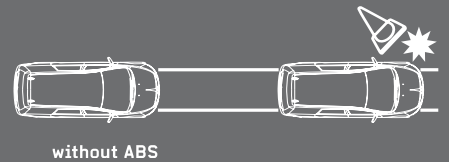

ABS allows you to maintain steering ability under hard braking conditions, thus avoiding obstacles. EBD (Electronic Brakeforce Distribution) automatically shifts the braking force between the front and rear wheels to reduce stopping distances – particularly helpful when your vehicle is loaded with cargo or passengers.



FORM MEETS FUNCTION MOST BEAUTIFULLY

Whilst you may be seduced by the Grandis' looks alone be assured that every inch has been designed with function in mind. That streamlined, bullet-shape is a tribute to the aerodynamicist's art, dressing the latest in chassis technology in such a way that you cleave the air cleanly and make the going less of a drag. Those striking, oversized rear light clusters and neat door mirror indicator repeaters ensure that your intentions will always be seen, with hi-tech LEDs instead of conventional bulbs for stronger illumination and faster response. This is family transport of the future, here today.

M-ASTC (Mitsubishi Active Stability and Traction Control) uses a combination of individual wheel braking and engine output control to maintain stability during cornering or sudden obstacle avoidance manoeuvres, and to enhance traction by applying braking to any wheel about to lose grip whilst reducing engine power. M-ASTC is fitted to Equipe and Elegance models.



D D D

AT THE HEART OF THE MATTER

Tradition says that you can't have your cake and eat it. Mitsubishi say why not? With its new turbo-charged, intercooled, 2.0 litre diesel engine with 16 valves and double overhead camshaft the Grandis achieves a sweet 134 bhp, 228 lb.ft. of torque at just 1750 rpm, and will power you from 0-62 mph in a mere 10.8 seconds.

Mated to this paragon of engineering is a six-speed manual transmission which employs a new Dual Mass Flywheel to make shifting less of a grind. So when you take a seat in front of that perfectly proportioned, leather-wrapped steering wheel and lift your eyes from those cool blue dials you will know that you're in for some fun.

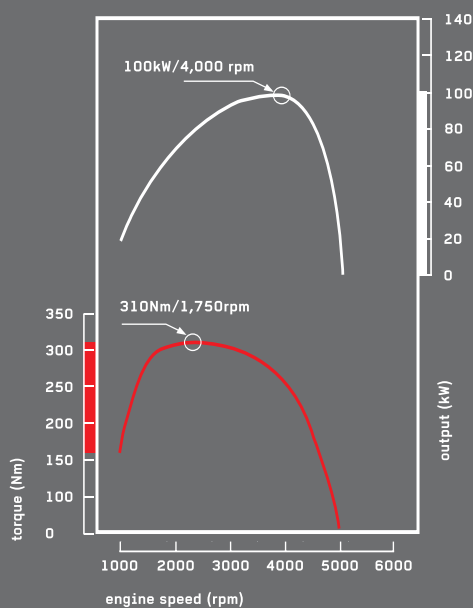

2.0 litre Diesel engine



High pressure pump jet technology means that the 2.0 litre diesel engine in the Grandis gives superb power and road-peeling torque, reaching a top speed of 121 mph (where legally permitted), yet returns a frugal 42.8 mpg on the combined cycle and is compliant with Euro IV emissions regulations.

Model illustrated: Grandis 2.0 DI-D Classic/Equippe



RELAX, THE OUTLOOK'S GRAND

In an age of ever-increasing stress the Grandis' interior is a place to chill – sumptuous fabrics and subtle curves are accentuated by the cool blue backlighting of the instrument panel, creating a calming atmosphere of comfort and well-being. The air conditioning allows you to control your own environment, with separate controls for those in the rear*; sounds from the CD player with MP3 capability add to the ambience, whilst electrically operated windows and door mirrors, central door locking, cruise control* and two separate sunroofs* add to the enjoyment of this fully-equipped family room on wheels.

*For full details of specification by model see page 26.





STORAGE TO PLEASE THE EYES

Modern families breed clutter. Kids don't come by themselves; they come with books and bags, shopping by the barrow-load, even with pets and playmates. Since Mitsubishi have been making multi-purpose vehicles for more than two decades they know a thing or two about the best way to keep all that clutter in check. Indeed, the Grandis boasts multiple holders for cups, pens, coins and glasses, as well as loads of ingeniously hidden storage spaces to satisfy the most active family, with plenty of pockets and trays that fold down for work or play. So even in use your Grandis will remain pleasing to the eye inside as well as out.









Model illustrated: Grandis 2.0 DI-D Classic/Equippe

SEATING FOR SEVEN

With its console mounted gearshift leaving a truly uncluttered floor area the Grandis sits seven in real comfort. Those in front are pampered with armrests as well as the ability to slide and recline to the optimum position. The second row bench seat includes ISO-Fix child seat mountings, adjusts for rake so that you can feel just right, and even splits 60:40 – the two sliding independently for maximum flexibility. The back row of seats feature Mitsubishi's highly praised Hide & Seat System, enabling you to fold it away completely in a matter of seconds for a spacious cargo area.





THESE SEATS DO TRICKS

The essence of an MPV is flexibility – whether your family is large or small you can be certain that it will be different sizes at different times – so give yourself time to explore all the options: slide the seats back and forward, tilt them or lay them flat, flip the third row over for a picnic, make up a bed or hide it away completely. You soon discover that, whilst it may not come with table, fridge or furry dice, the Grandis gives every permutation you'll ever need.



Hide & Seat System

This system allows the third row seats to fold away into the floor in a simple operation that takes seconds.

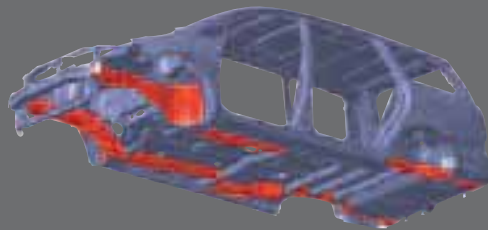

RISE (REINFORCED IMPACT SAFETY EVOLUTION)

The Grandis is built for strength – designed and constructed around an integrated platform with interconnecting structural elements which provide active passenger protection in the event of an accident.

SAFETY FAR BEYOND THE NORM

All cars are designed to safeguard life in the event of an accident but, as everywhere else, here the Grandis goes that little further. Of course it has loads of airbags. Of course it includes a deactivation facility for the front passenger seat in case you need to carry a child. Of course the ELR seatbelts incorporate pre-tensioners to help

prevent the injuries caused by violent stops, and all the powered windows and sunroof (where fitted) have anti-trapping mechanisms. But, for example, the Grandis also features a brand new seat frame design which helps to prevent the neck injuries so common with rear-end impacts; and a special design for the front seats ensures that

they stay locked to the chassis should you suffer a front-end collision. In a Grandis it's the little things which could save your life.



THE WARRIOR BREED

Every Grandis is an arresting living room on wheels: modern and edgy with handling as sharp as it looks, and supreme flexibility for a family and all their kit. But even amongst the very best living rooms some boast just a touch more style. Take the Grandis Warrior, for example – stunning in black or silver set off by the bright gleam of chrome, slick 18" alloy wheels and silver stitching to contrast with the deep black of its leather seats.

Furthermore, thanks to an in-car DVD entertainment system, in this Grandis not only the driver has fun.







REFLECT YOURSELF

Perfectly practical and practically perfect the Grandis diesel is the MPV you'll choose through desire, not necessity, and you can reflect your own personality by adding a wide range of Mitsubishi Motors genuine accessories. In addition to those shown here there is a whole brochure-full to choose from, just ask your dealer for the Grandis Accessories brochure. And remember, if fitted when new they all benefit from the same exceptional warranty as the vehicle itself.

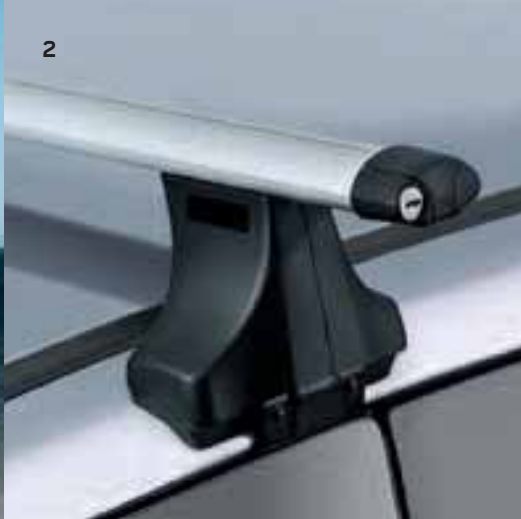

1. Chrome rear grip garnish/
Parking distance sensors
2. Roof carrier
3. Chromed door handles
4. Mudguards
5. Chromed door mirrors
6. Separation rack

Images are for illustrative purposes only
- designs may vary.

EXTERIOR AND INTERIOR



CLASSIC

The entry-level Grandis Classic enjoys power operated windows and door mirrors, fully automatic climate control air conditioning, a CD/MP3 player with six speakers and a leather-wrapped steering wheel and shift knob. A comprehensive safety specification includes ABS with EBD as well as front, side and curtain airbags and externally it benefits from 17" alloy wheels as well as colour-keyed door mirrors and handles.

EQUIPE AND ELEGANCE

In addition to the features enjoyed by the Classic the Grandis Equippe features two sunroofs (front manual, rear electric) as well as separate cooler controls for the rear and a CD autochanger. For the driver the Equippe benefits from cruise control and Mitsubishi's stability and traction control system (M-ASTC). To this generous specification the Elegance adds leather seat trim.



WARRIOR

A Classic turned Warrior has its mean 'n' moody black or gleaming silver paintwork enhanced with upper and lower chromed mesh front grilles as well as plenty of chrome in additional areas – exhaust, rear tailgate, door mirrors and handles; 18" Le Mans alloy wheels replace the 17" ones. The black leather interior is stitched with silver whilst a CD autochanger and DVD entertainment system ensure loads of fun.



STANDARD EQUIPMENT

1



1. Dual sunroofs
(Equippe and Elegance only)
2. Chrome outer door handles
(Warrior only)
3. Cruise control
(Equippe and Elegance only)
4. Colour-keyed door mirrors
(not available on Warrior)

2



3



4



COLOUR OPTIONS



Model		Grandis Classic	Grandis Equippe	Grandis Elegance	Grandis Warrior
Interior Trim		Black/Grey	Black/Grey	Black/Grey	Black/Grey
Exterior colour					
1 Sterling Silver (M)	A19	■	■	■	■
2 Graphite Grey (P)	A72	■	■	■	-
3 Thunder Blue (P)	T65	■	■	■	-
4 Polar White (S)	W32	■	■	■	-
5 Knight Black (P)	X24	■	■	■	■
Seats		Velour (Black/Grey)		Leather-faced (Black)	
Door Trim		Formed-type with Cloth Insert (Black)		Formed-type with Leather-look Insert (Black)	
Headlining		Non-woven Fabric (Grey)		Non-woven Fabric (Grey)	
Floor Carpet		Needle Punch (Black)		Needle Punch (Black)	

■ : Available - : Not available M: Metallic* P: Pearlescent* S: Solid

*Metallic/Pearlescent paint finish available at additional cost (standard on Warrior at no extra charge).

OUTSTANDING AFTER SALES FOR CAREFREE MOTORING

More than 2500 Mitsubishi Motors Authorised Service Points in Europe are committed to helping you wherever you are.

PROFESSIONAL SERVICING

Even new cars require regular maintenance and servicing. Not just to guarantee your mobility, but also for the safety of you and your passengers. Trained professionals using specialist diagnostic equipment and genuine parts at your Mitsubishi Authorised Service Point are ready to oblige.

You'll be advised about the cost beforehand, so there will be no unpleasant surprises when you return to pick up your vehicle.

MITSUBISHI MOTORS GENUINE PARTS

Even the smallest technical faults can lead to accidents. Therefore, all Mitsubishi Motors Genuine Parts have been developed and tested to stringent quality standards. We recommend using Mitsubishi Motors Genuine Parts in order to maintain the safety and integrity of your vehicle and that of your passengers. Mitsubishi Motors Genuine Parts are available at all Mitsubishi Authorised Service Points.

COMPREHENSIVE WARRANTY

All new Mitsubishi Grandis vehicles come with a comprehensive 3-year unlimited mileage warranty as standard. The anti-corrosion perforation warranty covers rusting through for the first 12 years. The reliability statistics for Mitsubishi vehicles are impressive, but in the unlikely event that you do need help, we offer MAP.

MAP - FREE BREAKDOWN ASSISTANCE



Throughout the warranty period your vehicle is covered by Mitsubishi Motors Assistance Package (MAP) roadside assistance. This cover extends to more than 30 countries throughout Europe so your mobility is guaranteed even when you are on holiday. Should you ever need assistance in the event of breakdown, accident, theft or

vandalism - wherever you are, 24 hours a day, 7 days a week - just call the number on your card and the problem will be fixed on the spot. If it's more serious, your car will be taken to the nearest Mitsubishi Authorised Service Point and you'll be offered services such as a hotel, continuation of journey, a replacement car and vehicle repatriation. And if you continue to have your vehicle serviced at a Mitsubishi Authorised Service Point after the first three years, your mobility will be guaranteed for an additional year or up to the next service interval (whichever comes first) until your vehicle is 10 years old.

MAJOR SPECIFICATIONS

Model		Grandis 2.0 DI-D Classic	Grandis 2.0 DI-D Equippe	Grandis 2.0 DI-D Elegance	Grandis 2.0 DI-D Warrior	
Engine						
Engine type		2.0 Litre 4-cylinder 16-valve DOHC DI-D Intercooled Turbocharged Diesel				
Fuel system		Electronically controlled direct injection fuel pump				
Displacement	cc	1968	1968	1968	1968	
Bore/stroke	mm	81.0 x 95.5	81.0 x 95.5	81.0 x 95.5	81.0 x 95.5	
Compression ratio		18.0	18.0	18.0	18.0	
Max. output	kw (bhp) at rpm	100(134)/4000	100(134)/4000	100(134)/4000	100(134)/4000	
Max. torque	Nm (lb.ft) at rpm	310(228)/1750	310(228)/1750	310(228)/1750	310(228)/1750	
Performance/Fuel Consumption/Emissions						
Maximum speed	mph (kph)	121 (195)	121 (195)	121 (195)	121 (195)	
Acceleration 0-62 mph	secs	10.8	10.8	10.8	10.8	
Fuel type		Diesel	Diesel	Diesel	Diesel	
Fuel consumption	Urban	8.4 (33.6)	8.4 (33.6)	8.4 (33.6)	8.4 (33.6)	
lts/100km (mpg)	Extra urban	5.6 (50.4)	5.6 (50.4)	5.6 (50.4)	5.6 (50.4)	
	Combined	6.6 (42.8)	6.6 (42.8)	6.6 (42.8)	6.6 (42.8)	
CO ₂ emissions	g/km	176	176	176	176	
Suspension and Steering						
Front axle		MacPherson Strut Coil Springs with Stabiliser Bar				
Rear axle		Semi-Trailing Arm Coil Springs with Stabiliser Bar				
Brakes		Anti-lock Braking System with Electronic Brakeforce Distribution (ABS with EBD) and Brake Assist				
	Front	11.4" Ventilated Disc Brakes (2-pot)				
	Rear	7.5" Solid Drum-in-Disc Brakes				
Steering		Rack & Pinion, Power Assisted				
Min. turning circle	m (ft)	11.6 (38.1)	11.6 (38.1)	11.6 (38.1)	11.6 (38.1)	
Tyres		215/55R17 94V	215/55R17 94V	215/55R17 94V	235/45R18 98W	
Wheels		17" x7JJ Alloy	17" x7JJ Alloy	17" x7JJ Alloy	18" x 8JJ Alloy	
Driveline/Transmission						
Type		Front Transverse Engine/Front Wheel Drive				
Clutch	Manual	Hydraulic				
Transmission		Manual	Manual	Manual	Manual	
Manual		6 Speed	6 Speed	6 Speed	6 Speed	
Gear ratios	1st	3.583	3.583	3.583	3.583	
	2nd	2.045	2.045	2.045	2.045	
	3rd	1.366	1.366	1.366	1.366	
	4th	0.974	0.974	0.974	0.974	
	5th	0.897	0.897	0.897	0.897	
	6th	0.790	0.790	0.790	0.790	
	Reverse	3.831	3.831	3.831	3.831	
Final gear ratio	1st-4th	4.058	4.058	4.058	4.058	
Final gear ratio	5th, 6th, reverse	3.450	3.450	3.450	3.450	
Dimensions						
Cargo room l x w x h	min.	mm	440 x 1260 x 1100	440 x 1260 x 1100	440 x 1260 x 1100	440 x 1260 x 1100
	max.	mm	1600 x 1520 x 1140	1600 x 1520 x 1140	1600 x 1520 x 1140	1600 x 1520 x 1140
Cargo capacity	min.	lts VDA (cu.ft.)	320 (11.3)	320 (11.3)	320 (11.3)	320 (11.3)
	max.	lts VDA (cu.ft.)	1545 (54.55)	1545 (54.55)	1545 (54.55)	1545 (54.55)
Exterior l x w x h		mm	4765 x 1795 x 1655	4765 x 1795 x 1655	4765 x 1795 x 1655	4765 x 1795 x 1655
Ground clearance (unladen)		mm	155	155	155	155
Track Front		mm	1550	1550	1550	1550
	Rear	mm	1555	1555	1555	1555
Wheelbase		mm	2830	2830	2830	2830
Weights/Volumes						
Seating capacity		7	7	7	7	
Fuel tank capacity	lts (imp.galls)	65 (14.3)	65 (14.3)	65 (14.3)	65 (14.3)	
Gross vehicle weight	kg (lbs)	2335 (5149)	2335 (5149)	2335 (5149)	2335 (5149)	
Kerb weight	kg (lbs)	1785 (3935)	1785 (3935)	1785 (3935)	1785 (3935)	
Towing capacity, braked	kg (lbs)	2000 (4410)	2000 (4410)	2000 (4410)	2000 (4410)	
Trailer nose weight	kg (lbs)	85 (187)	85 (187)	85 (187)	85 (187)	
Roof loading capacity	kg (lbs)	65 (143)	65 (143)	65 (143)	65 (143)	
Servicing/Insurance/Warranty						
Service intervals		Every 9,000 miles or 12 months, whichever occurs first				
Insurance group		13D	14D	14D	15D	
Warranty		3 years unlimited mileage warranty, 12 years anti-corrosion perforation warranty, 3 years pan-European roadside, home and accident assistance				

STANDARD AND OPTIONAL EQUIPMENT

Model	Grandis 2.0 DI-D Classic	Grandis 2.0 DI-D Equippe	Grandis 2.0 DI-D Elegance	Grandis 2.0 DI-D Warrior
Security and Safety Features				
Security				
Alarm/keyless entry	■	■	■	■
Immobiliser, engine	■	■	■	■
Locking wheel nuts	■	■	■	■
Luggage cover, retractable	DFO	■	■	■
Mighty Dot security	■	■	■	■
Visible VIN	■	■	■	■
Safety				
ABS with EBD and Brake Assist	■	■	■	■
Airbag, front passenger deactivation switch	■	■	■	■
Airbag SRS, driver's and front passenger's	■	■	■	■
Airbag SRS, front seat sides x 2	■	■	■	■
Airbag SRS, curtain type, 1st and 2nd row	■	■	■	■
Child proof rear door locks	■	■	■	■
Disc brakes, ventilated front, solid rear	■	■	■	■
Electric anti-trapping windows, front, with drivers one-touch operation	■	■	■	■
Electric anti-trapping windows, rear	■	■	■	■
Fog lamp, rear	■	■	■	■
ISO-Fix child seat mountings, 2nd row	■	■	■	■
Mitsubishi Active Stability and Traction Control (M-ASTC)	-	■	■	-
Rear spoiler with 18 LED stop lamp	■	■	■	■
Seatbelts, ELR with pretensioners and force limiters, front	■	■	■	■
Seatbelts, ELR/ALR 3-point x 3, 2nd row	■	■	■	■
Seatbelts, ELR/ALR 3-point x 2, 3rd row	■	■	■	■
Exterior Features				
Styling				
17" alloy wheels	■	■	■	-
18" alloy wheels	-	-	-	■
Bumpers, colour keyed, front and rear	■	■	■	■
Chrome exhaust trim	DFO	DFO	DFO	■
Door mirrors and handles, colour keyed	■	■	■	-
Door mirrors and handles, chrome	DFO	DFO	DFO	■
Front grille, sports type	DFO	DFO	DFO	■
Metallic or pearlescent paint finish	□	□	□	■
Tailgate grip, chrome	DFO	DFO	DFO	■
Functional				
Door mirrors, elec adjustable and heated, colour keyed	■	■	■	-
Door mirrors, elec adjustable and heated, chrome	DFO	DFO	DFO	■
Door mirrors, electrically foldable	■	■	■	■
Fog lamps, reflector type, front	■	■	■	■
Rear combination lamp unit, 24 LED	■	■	■	■
Remote central door locking	■	■	■	■
Side indicators, door mirror mounted, 6 LED	■	■	■	■
Spare wheel, space saver, under rear floor	■	■	■	■
Wipers, variable intermittent with washer, front	■	■	■	■
Wiper, intermittent with washer, rear	■	■	■	■
Interior Features				
Audio				
Aerial, element type, in rear side window	■	■	■	■
CD Autochanger	DFO	■	■	■
RDS (Radio Data System) information	■	■	■	■
DVD Entertainment system with 8" screen, roof mounted	DFO	DFO	DFO	■
Stereo radio/CD with MP3 compatibility and 6 speakers	■	■	■	■
Styling				
Door handles, silver	■	■	■	■
Door trim inserts, fabric, black	■	■	-	-
Door trim inserts, leather-look, black	□	□	■	■
Electric window switch panels, silver with mesh print	■	■	■	■
Floor mats with Warrior logo	-	-	-	■
In-dash gearshift panel, silver with mesh print	■	■	■	■
Instrument meters, 3-stage lighting, blue	■	■	■	■
Leather-faced seats, black	□	□	■	-
Leather-faced seats, black with Warrior logo	-	-	-	■
Leather-wrapped steering wheel, 4-spoke, black	■	■	■	■
Leather-wrapped gearshift knob, black	■	■	■	■
Seat trim, velour, black/grey	■	■	-	-
Convenience				
Air conditioning, climate control with pollen filter	■	■	■	■
Ashtray and cigarette lighter, illuminated	■	■	■	■
Bottle and cup holders, front, 2nd and 3rd row	■	■	■	■
Cargo floor storage box x 2	■	■	■	■
Cargo room net and hook	■	■	■	■
Credit card slot	■	■	■	■
Cruise control	-	■	■	-
Dashboard, upper centre box with lid	■	■	■	■
Door pockets, front and rear	■	■	■	■
Floor console tray with cup, pen and coin holder	■	■	■	■

■ : Standard □ : Option at additional cost - : Not available DFO : Dealer Fit Option at additional cost

STANDARD AND OPTIONAL EQUIPMENT

Model	Grandis 2.0 DI-D Classic	Grandis 2.0 DI-D Equippe	Grandis 2.0 DI-D Elegance	Grandis 2.0 DI-D Warrior
Interior Features continued				
Convenience				
Footrest, driver's	■	■	■	■
Glovebox, lockable and illuminated	■	■	■	■
Ignition keyhole with time delay, illuminated	■	■	■	■
Lights-on warning buzzer	■	■	■	■
Luggage cover, retractable	DFO	■	■	■
Rear manual cooler controls	-	■	■	-
Retractable assist grips x 6	■	■	■	■
Seatback trays x 2, foldable, 2nd row	■	■	■	■
Sunglasses holder	■	-	-	■
Sunvisors, driver's and passenger's, illuminated	■	■	■	■
Functional				
Average fuel consumption display	■	■	■	■
Average speed display	■	■	■	■
Centre multi-info display	■	■	■	■
Demister with auto-off timer, rear window	■	■	■	■
Digital quartz clock	■	■	■	■
Exterior temperature display	■	■	■	■
Fuel lid opener, remote	■	■	■	■
Fuel range indicator	■	■	■	■
Headlamp levelling device	■	■	■	■
Instrument panel dimmer	■	■	■	■
Steering wheel, tilt adjustable	■	■	■	■
Sunroof, dual, front manual tilt, rear electric sliding	-	■	■	-
Lighting				
Door courtesy lamps, front and rear	■	■	■	■
Interior lamp and map reading lamps, front	■	■	■	■
Luggage/cargo area lamp	■	■	■	■
Personal lamps, rear	■	■	■	■
Seats				
Driver's seat height adjustment	■	■	■	■
Front seats, centre armrests	■	■	■	■
Front seats, adjustable slide and recline	■	■	■	■
Head restraints, front – height and tilt adjustable x 2	■	■	■	■
Head restraints, 2nd row – height adjustable x 3	■	■	■	■
Head restraints, 3rd row – large type x 2	■	■	■	■
Seats, 2nd row – ISO-Fix child seat mountings	■	■	■	■
Seats, 2nd row – centre armrest, folding	■	■	■	■
Seats, 2nd row – 60:40 split bench, tip-up and sliding	■	■	■	■
Seats, 2nd row – seat rake angle adjustment	■	■	■	■
Seats, 3rd row – 50:50 individual type, folding	■	■	■	■
Seats, 3rd row – individually fold flat into floor	■	■	■	■
Seats, 3rd row – tip reverse seat function	■	■	■	■

■ : Standard □ : Option at additional cost - : Not available DFO : Dealer Fit Option at additional cost

DIMENSIONAL VIEWS

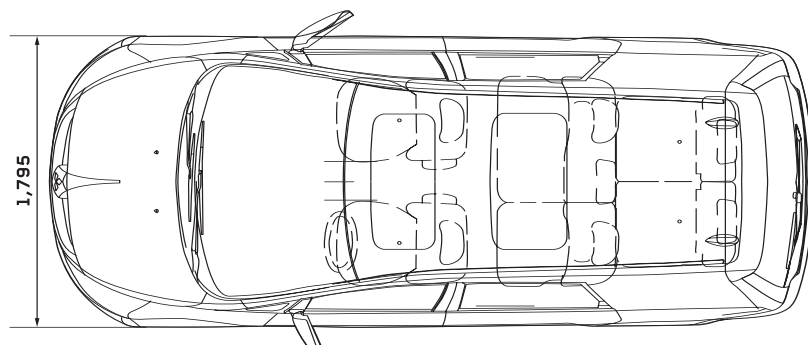
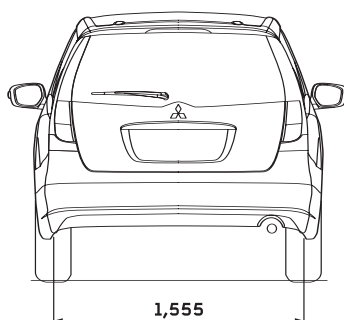
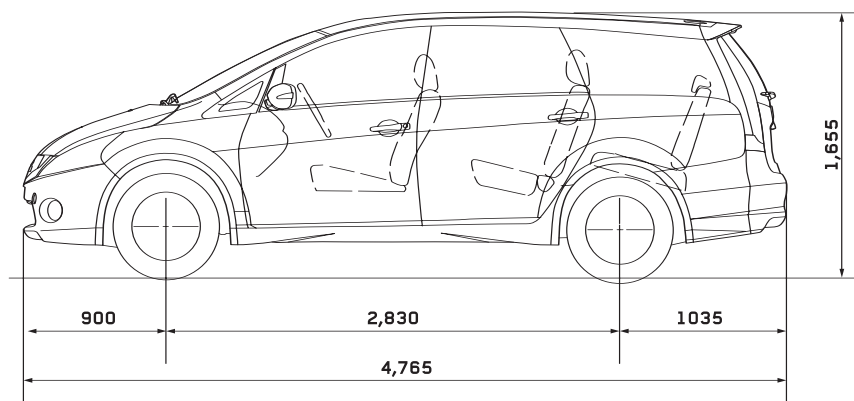
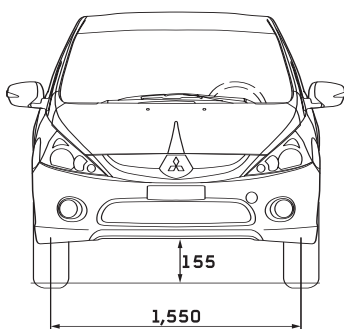

All measurements in millimetres.



DRIVE ALIVE IS OUR MOTTO.

It's the reason our designers and engineers go to work everyday. Statistics show that you are going to spend 'years of your life' in your car. We want those 'years' to be as pleasurable and as rewarding for you as possible. We want to ensure that every time you're driving and put your foot down on the accelerator, or catch a glimpse of yourself reflected... you will want to smile. Smile to really feel alive... to really drive alive.

Mitsubishi Motors Europe BV
www.mitsubishi-motors-europe.com

Specifications and warranty conditions may vary for overseas markets. For personal export, NATO or diplomatic sales, please refer to the appropriate 'Export Department' as follows:
U.K.: The Colt Car Company Ltd., Watermoor, Cirencester, Glos. GL7 1LF. Tel: 01285 655777.
Germany: The Colt Car Company Ltd., P.O. Box 1244, 41374 Brüggen, Germany. Tel: 02163 7036.

The specification of the vehicles illustrated in this publication may not be applicable to the UK market, furthermore some vehicle illustrations may include accessory items which are not part of UK standard specification. However, every effort has been made to ensure that the written information was accurate, up-to-date and consistent with UK specification at the time of going to press. The right is reserved to change specification, features and prices without prior notice. To avoid any misunderstandings, your Mitsubishi Motors dealer will advise of any alterations made since the date of issue of this brochure. No part of this publication may be reproduced in any form or by any means, without the prior written permission of The Colt Car Company Limited.

Head Office: The Colt Car Company Ltd., Watermoor, Cirencester, Glos. GL7 1LF
Tel: 01285 655777 Fax: 01285 658026 Website: www.mitsubishi-cars.co.uk

GRAN5006 08/05